

Issues

MANDATORY BULLETIN No. EV 97 – 003a

1. **REFER TO :** Ultralight aircraft EV-97 EUROSTAR, S/N 9700X2, 9700X3, 980101- 980106, 980201-980206, 980301-980308, 980401-980404, 990501-990505
2. **REASON:** During SLZ EV-97 EUROSTAR operation the case of crack creation was registered on the main tube of the nose landing gear leg.
3. **REQUIRED ACTION :** To perform visual inspection (by the means of the magnifying glass with 5x magnification) of the nose landing gear leg in the area of the welding joint in the point identified in the picture (appendix No. 1) In case the crack creation is identified it is necessary to perform the repair of the nose landing gear leg (crack shall be welded) and reinforce it (to make a contact to manufacturer). In case the break is not identified the inspection shall be repeated after each 50 flying hours or after 200 landings, what is sooner.
4. **LATEST DATE OF THE ACTION:** Immediately upon bulletin receipt.
5. **ACTION CARRIED OUT BY :** Operator (owner) shall perform the inspection, in case of the break the dismounting of the leg (according to drawing and procedure), the manufacturer shall perform repair or removal of the leg.
6. **INDUCED COST COVERED BY:** Leg repair itself shall be settled by the manufacturer.
7. **NECESSARY MATERIAL:** It shall be provided by the manufacturer.
8. **PROCESS :** See appendix No. 1
9. **ENCLOSURE:** Appendix No. 1 –the drawing and the procedure of dismounting and mounting of the leg.

AEROTECHNIK CZ

s. r. o.

686 04 KUNOVICE

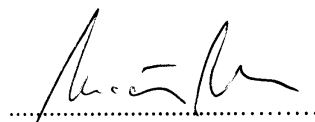

.....
Manufacturer approval

Date: June 1,1999



.....
Light Aircraft Authority approval

Date: 6. 01. 1999

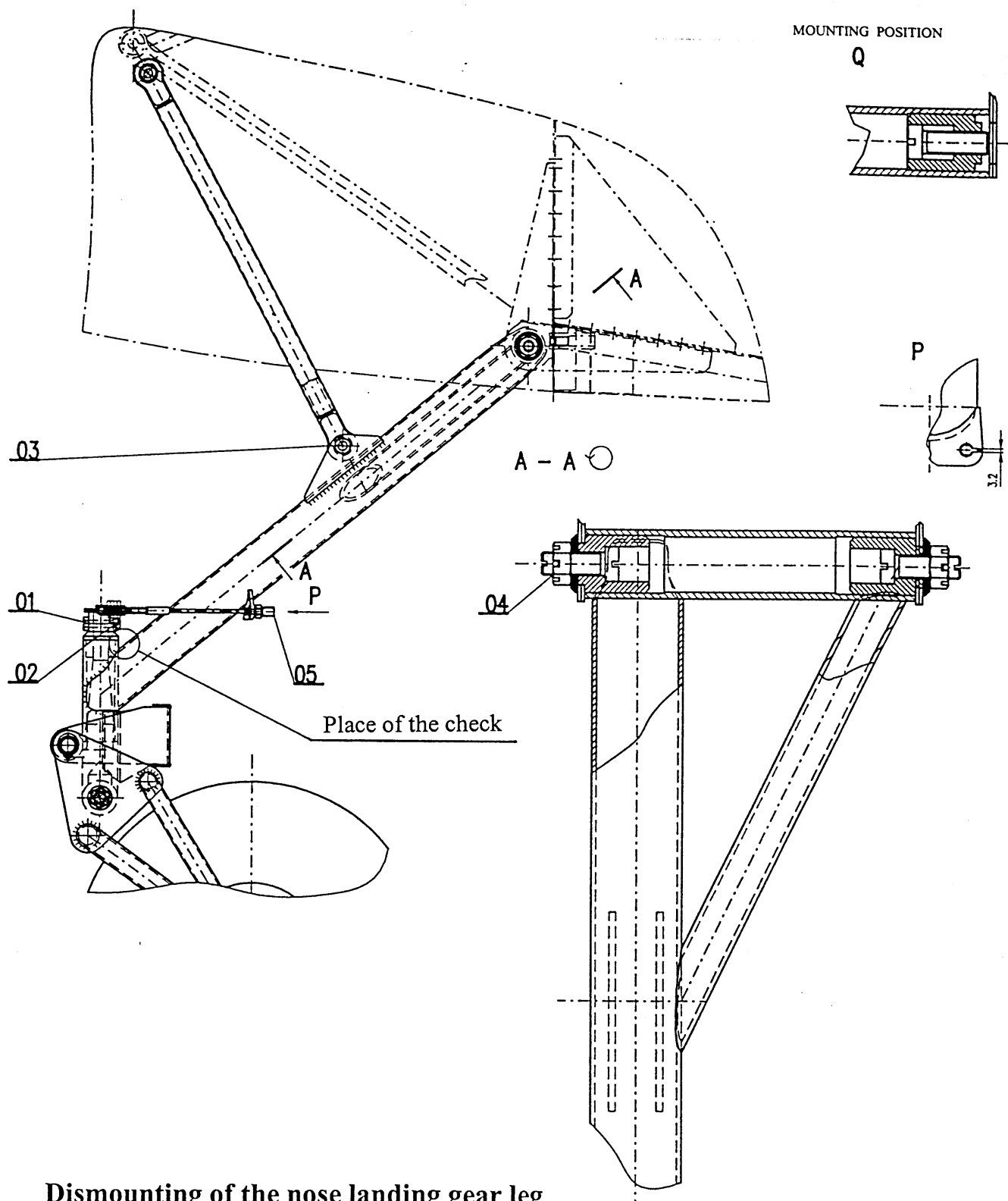

Dismounting of the nose landing gear leg

1. Dismount the control lever of nose landing gear by the removal of the bolt - position No. 01 and position No. 02
2. Push out the released centre with fork and silentblock from the fit in the leg towards down
3. Unscrew the link for control ropes - position No. 05 and take out the ropes from the strut (in case of older leg design it necessary to cut through the groove according to view P)
4. Dismount threaded joint with the strut of nose landing gear - position No. 03
5. Release and screw together M10 nuts at the connection of landing gear to the fuselage - position No. 04
6. Push in M10 bolts according to the picture Q and remove the leg from the fuselage.
7. Remounting of repaired leg shall be performed as dismounting but in the opposite sequence of operations